



PROJECT		REF		REV	ITEM CODE	
LOCATION		DATE			PAGE	

SANITARY WARE SPECIFICATION SHEET

Item Descriptions	Inax (Japan) Chrome plated deck mounted Infra-red extended sensor thermostatic mixer; DC Supply with 4x AA size alkaline cell battery	Illustration/ Drawing
Dimensions	L127 x W51 x H283 mm	
Model	AM-320HTC	
Finish	Chrome Plated	
Manufacturer	Inax (Japan)	
Source	Acme Sanitary Ware Co. Ltd Mr. Eric Wong/ Mr. Don Yuen	
Contact Tel/Fax	(852) 2388-7171 / (852) 2710-8012	
E-mail	acme@acmesanitary.com.hk	
Website	www.acmesanitary.com.hk	

- Deck Mounted Sensor Thermostatic Mixer
- Not included drain pop-up
- Power: Aqua Energy Hydraulic Generator: DC7V
- Back-up: 4x AA size alkaline cell battery
- Water pressure: 0.05MPa (Flow) to 0.75MPa (Static)
- For thermostatic variants, cold water pressure shall not be lower than hot water pressure
- Ambient Temperature: 0 to 40 degrees Celsius
- Ambient Humidity: Not higher than 90 %RH
- Flow Rate: 2 to 3 L/min (with flow restrictor @2.5 L/min)
- Sensing: Distance-measuring IR sensor
- Sensing Distance: Automatically Adjusted
- Size Of Sensing Area: Dia. 10 mm
- Inlet Connection: Single: R1/2 / Thermostatic: PJ 1/2 screw

仕様		
電源	主電源	DC7V(電源回路)
	バックアップ	DC3V(アルカリ乾電池単3形4本)
使用圧力範囲	0.05(流動時)~0.75(静止時)MPa 水圧 ≥ 湯圧	
使用水	水道水および飲用可能な井戸水	
使用環境温度範囲	0~40℃	
使用環境湿度範囲	90%RH以下	
適正流量範囲	2~3L/分(2.5L/分定流量弁内蔵)	
感知方式	距離測定式赤外線センサー	
感知距離	自動設定(感知距離自動調整機能内蔵)	
感知エリア幅	約φ10mm	

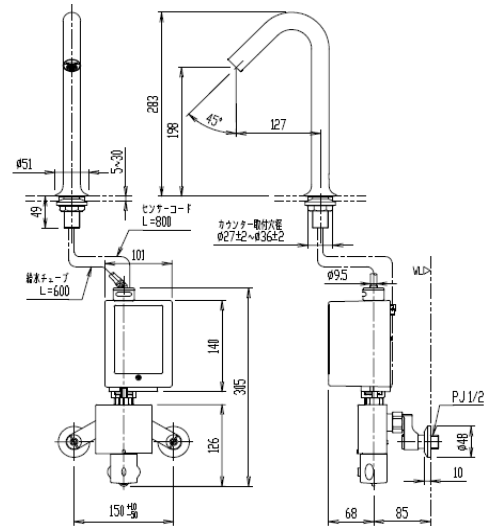

* All information of the above is for the reference only. No prior notice is made if any changes.



PROJECT		REF		REV	ITEM CODE	
LOCATION		DATE			PAGE	

SANITARY WARE SPECIFICATION SHEET

番号	部品品番	部品名	所要数
1	A-11026-10	吐水口ASSY	1
2	A-8216	45° 継手ASSY	1
3	A-11028	機能BOX	1
4	72-1057	クイックファスナー (呼び12.7)	1
5	A-8187	定流量弁ASSY	1
6	A-8186-1	サーモスタットASSY	1
工	KG-4	締付レンチ	1

ベッセル型洗面器と組み合わせて
使いやすい高さのタイプも用意
しています。

Note:

** All information of the above is for the reference only. No prior notice is made if any changes.*



水務署
Water Supplies Department

總部 Headquarters

香港灣仔告士打道七號入境事務大樓 48 樓

48 Gloucester Tower, 7 Gloucester Road, Wan Chai, Hong Kong

本署檔號
Our ref.
來函檔號
Your ref.



2024 T/J(303/2024)

電話 :
Tel. :
傳真 : 2824 0578
Fax. :

2 May 2024

**Approval of "INAX" Thermostatic Mixer
(General Acceptance No. C20240286)**

Your E-Application [file-id: ETJ-GA-20240327-55] dated 10 April 2024 refers.

Having considered the test reports ref. 220188PC220016B and 202535EN220249(2) issued on 27 March 2024 and 21 April 2022 by Fugro Technical Services Ltd., this Authority accepts that the fitting described below complies with, and its use when correctly installed does not contravene, the Waterworks Ordinance and Regulations.

Name of Manufacturer: LIXIL Corporation
Country of Origin: Japan
Brand: INAX
Details of Fitting: 1/2" Deck mounted thermostatic sensor mixer with 1 no. of flexible hose
Model: AM-320HTC
Body Markings: INAX



Expiry Date: 31 March 2027

This Authority hereby permits the use of the above fitting in fresh water plumbing systems subject to full adherence to Waterworks installation requirements. In particular, you are required to draw your customers' attention to the following requirement-

"The cold water supply to the fitting shall be drawn from the same source that supplies the hot water apparatus so as to provide a balanced pressure and to obviate the risk of scalding in the event of a restriction or failure in the water supply."

"A stop cock or gate valve must be installed at the upstream of the fitting for manual isolation of water supply." AND

"The main voltage operated sensor valve should comply with the electricity safety regulation for applications in bathroom, toilet etc."

A condition of this acceptance is that the fitting to be installed shall be replicas of the sample as certified by the testing agent mentioned above and without modifications. This acceptance may be withdrawn at any time if the standard of the fitting installed fails to meet that of the approved sample or if the fitting is found to be unsuitable for use in fresh water plumbing systems.

This acceptance is only applicable to the main body of the fitting, unless otherwise specified.

For the use of the fitting in any project, the General Acceptance Number of this letter must be quoted as a means of identification of acceptance of the fitting by this Authority.

Should you have any enquiries, please contact our Engineer Mr Albert CHOW at tel. no. 3583 4086.

Yours faithfully,



(Terry KUNG)

for Director of Water Supplies

Encl.

c.c. WSD 3321/1/82] - without catalogue
ME/MC] - with soft copy only